

EXTERNAL ELEVATION OF SLIDE DOORS
1:20 @ A1

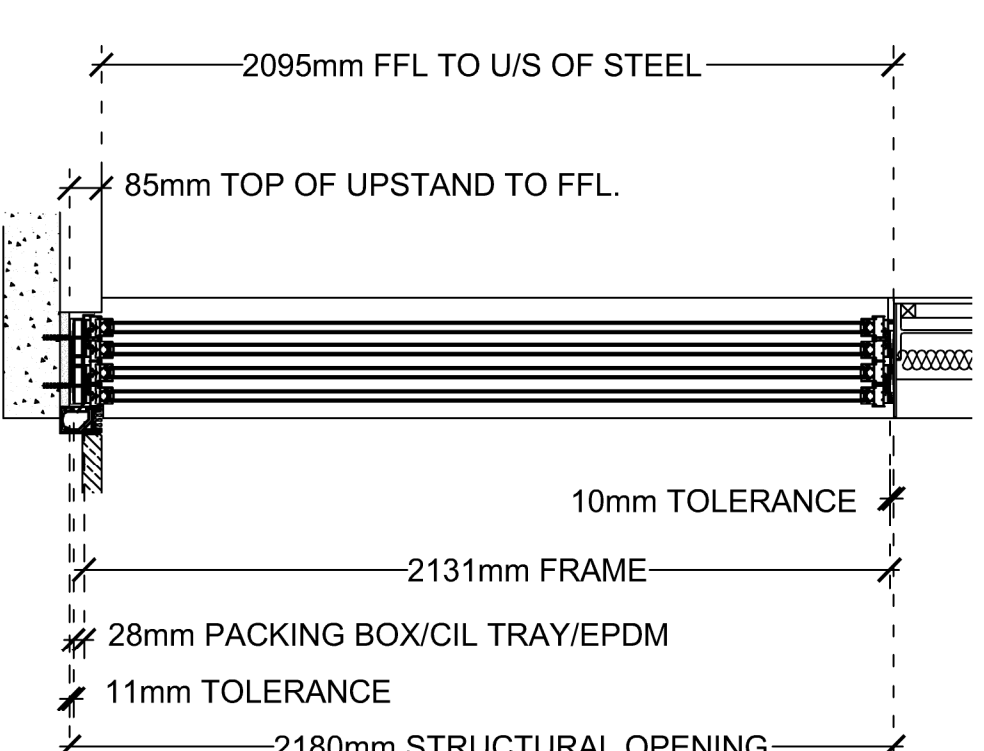

SECTION THROUGH OF SLIDE DOORS
1:20 @ A1

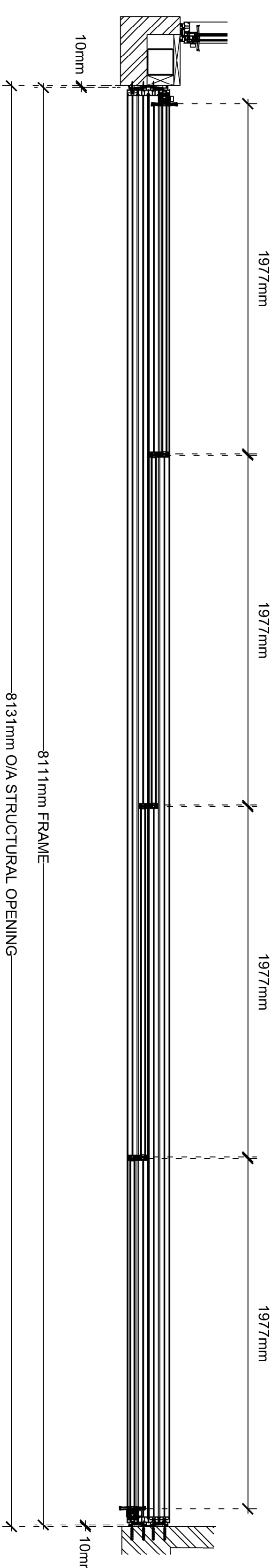

PLAN VIEW OF SLIDE DOORS
1:20 @ A1

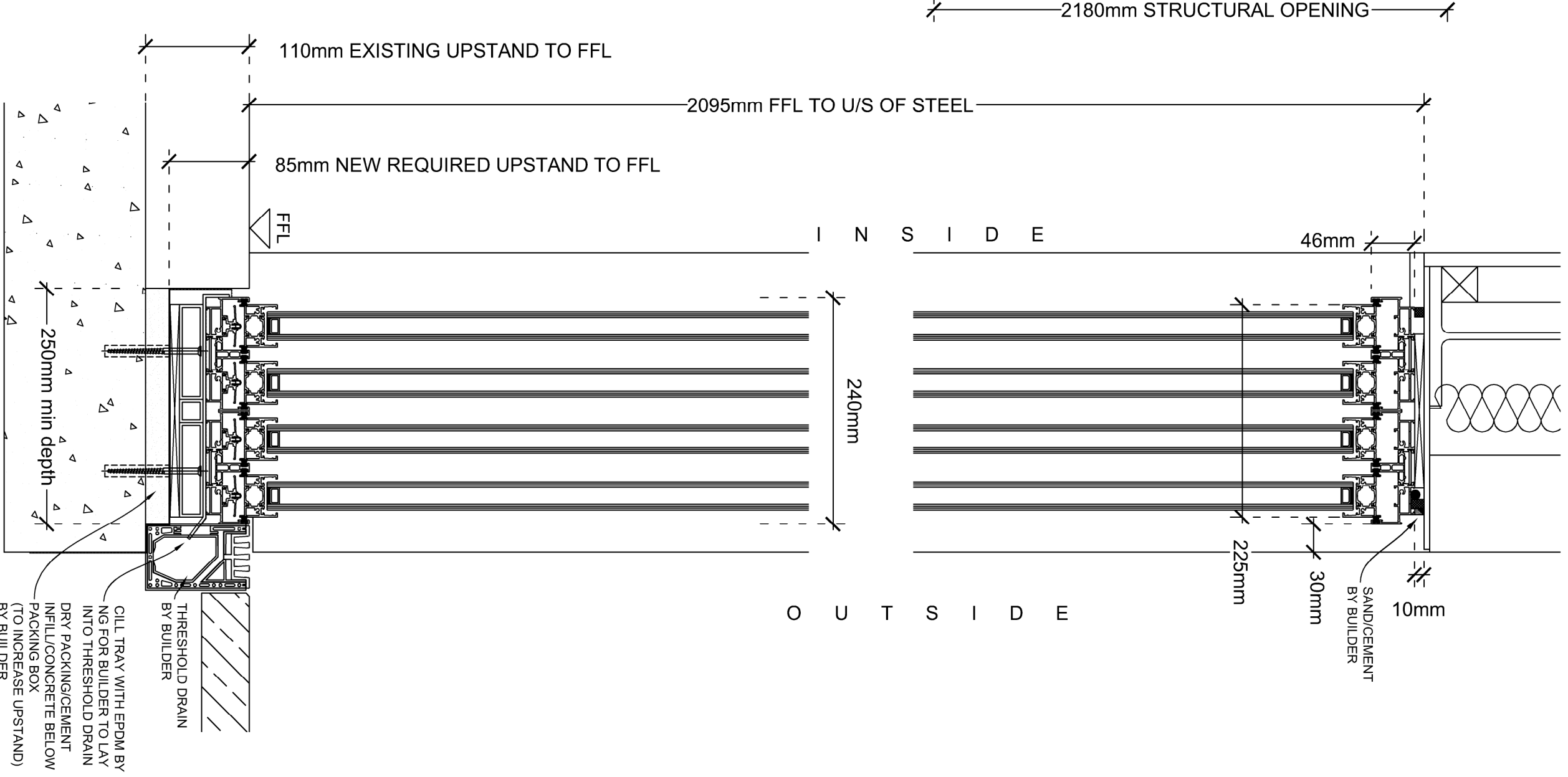

APPROVED FOR PRODUCTION
05.07.19

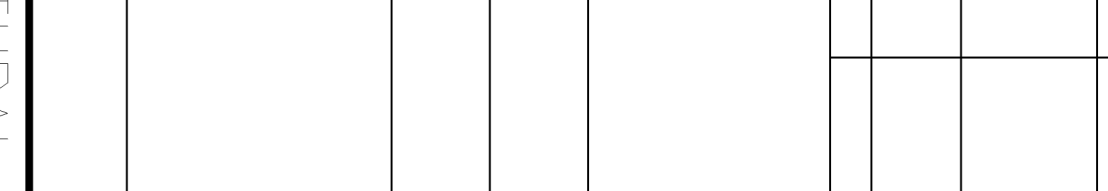
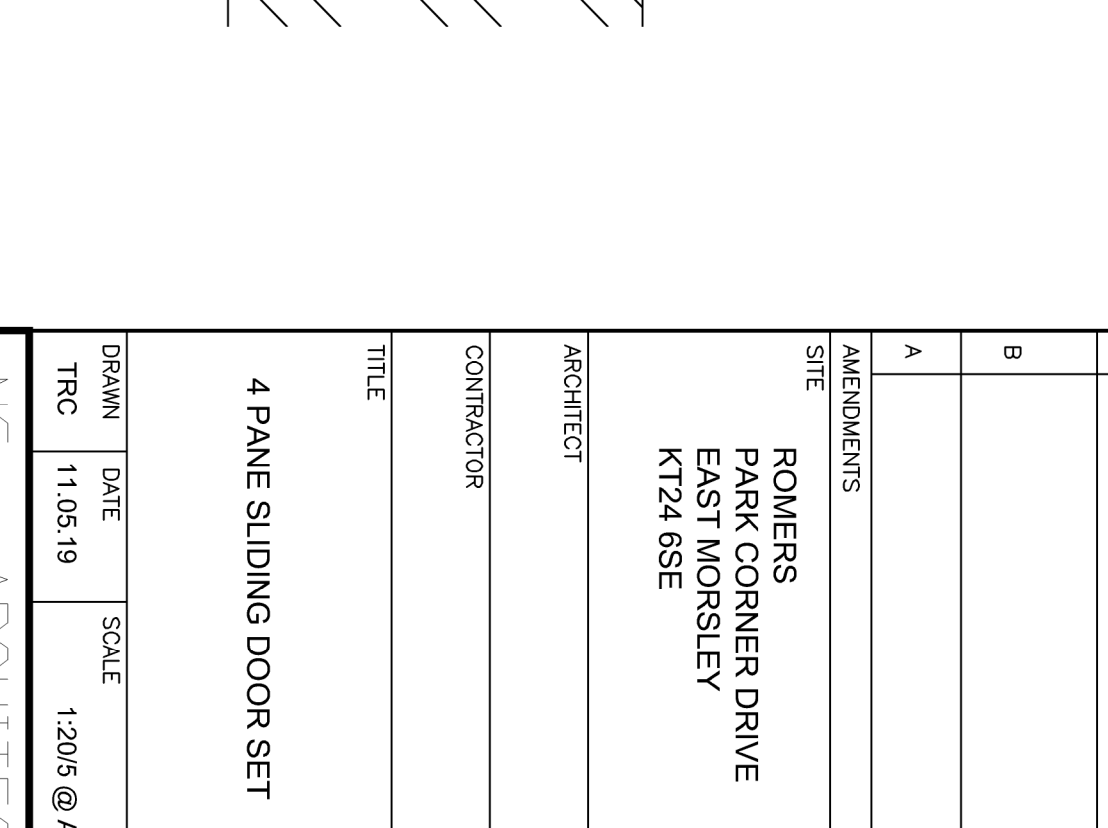
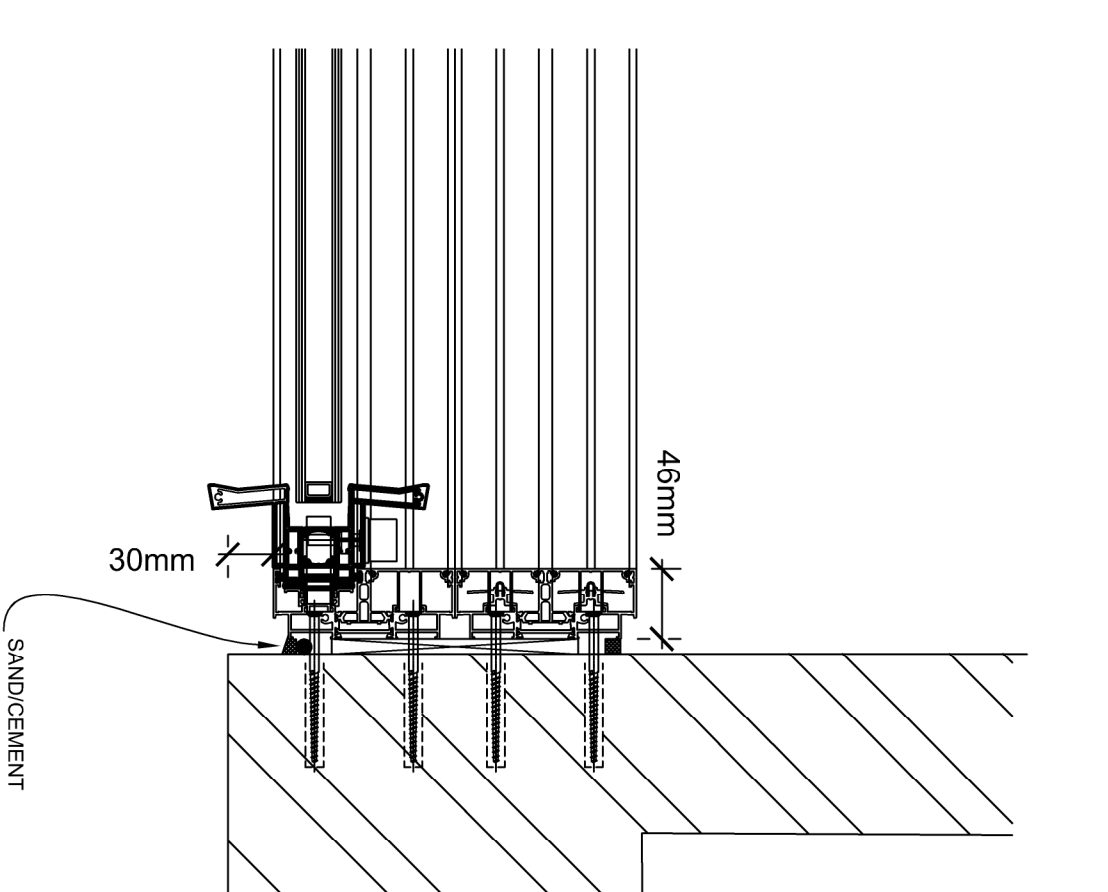
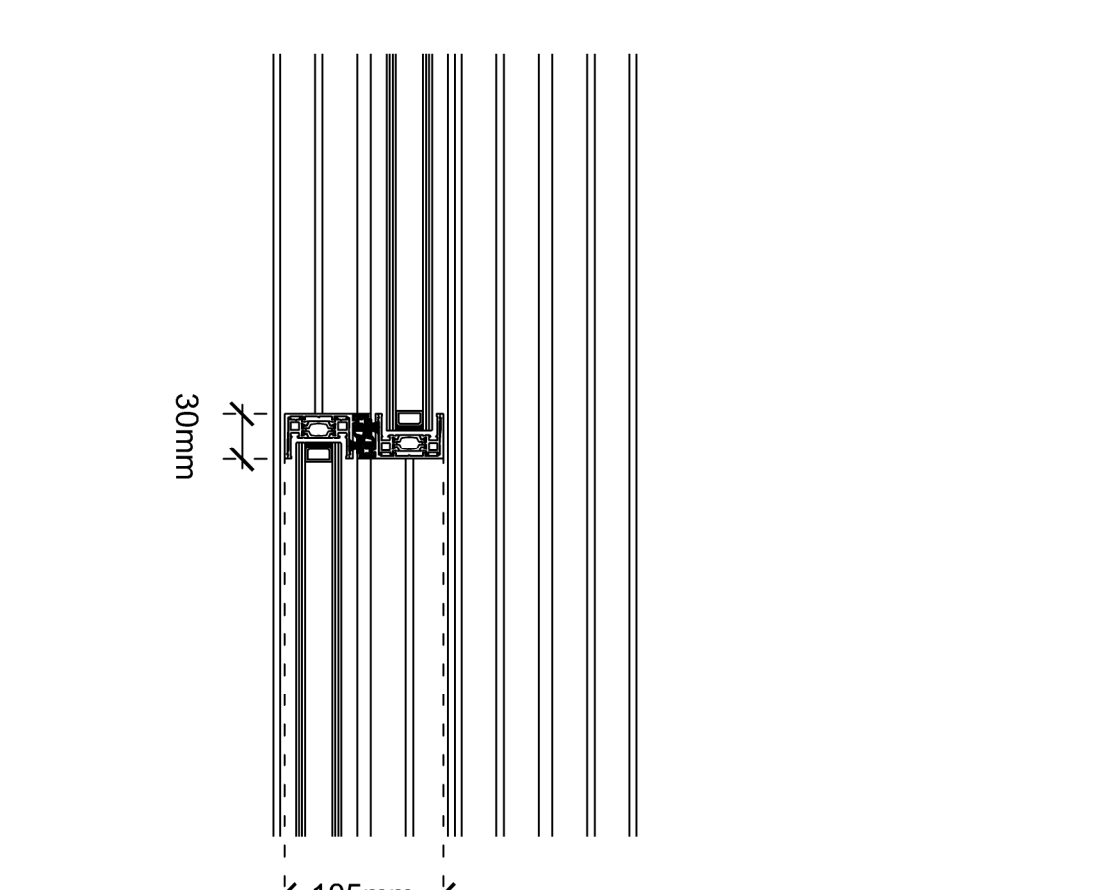
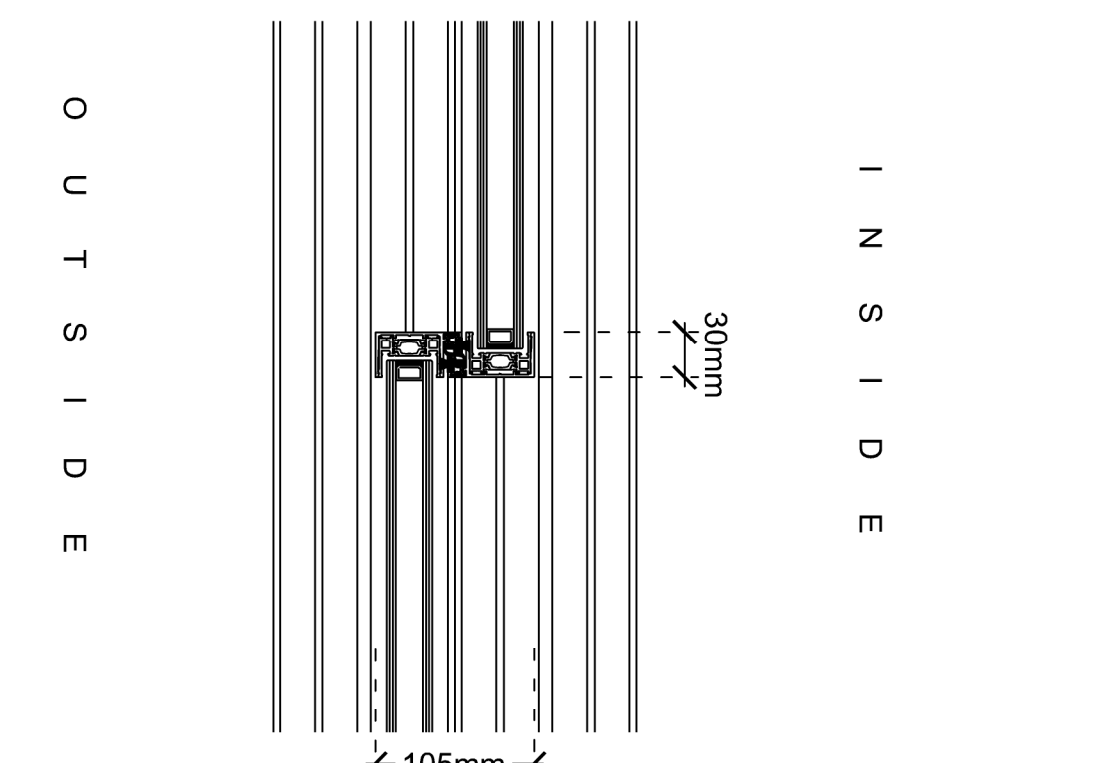
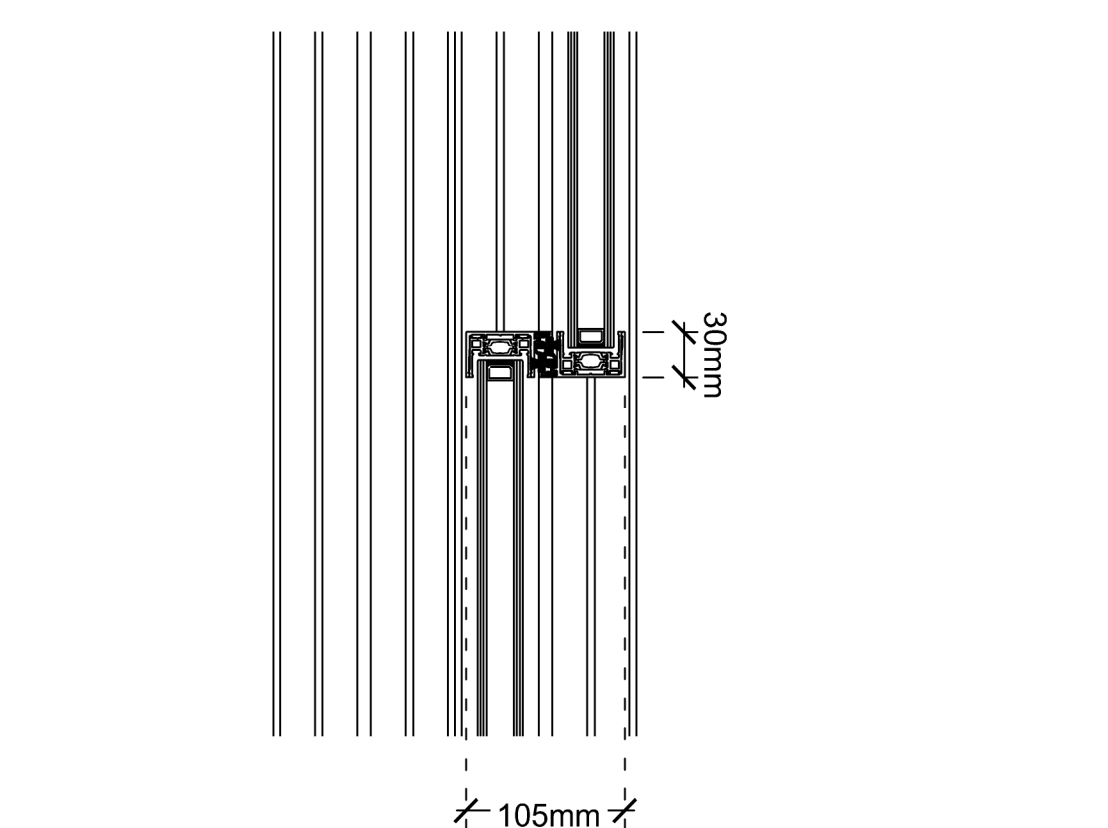
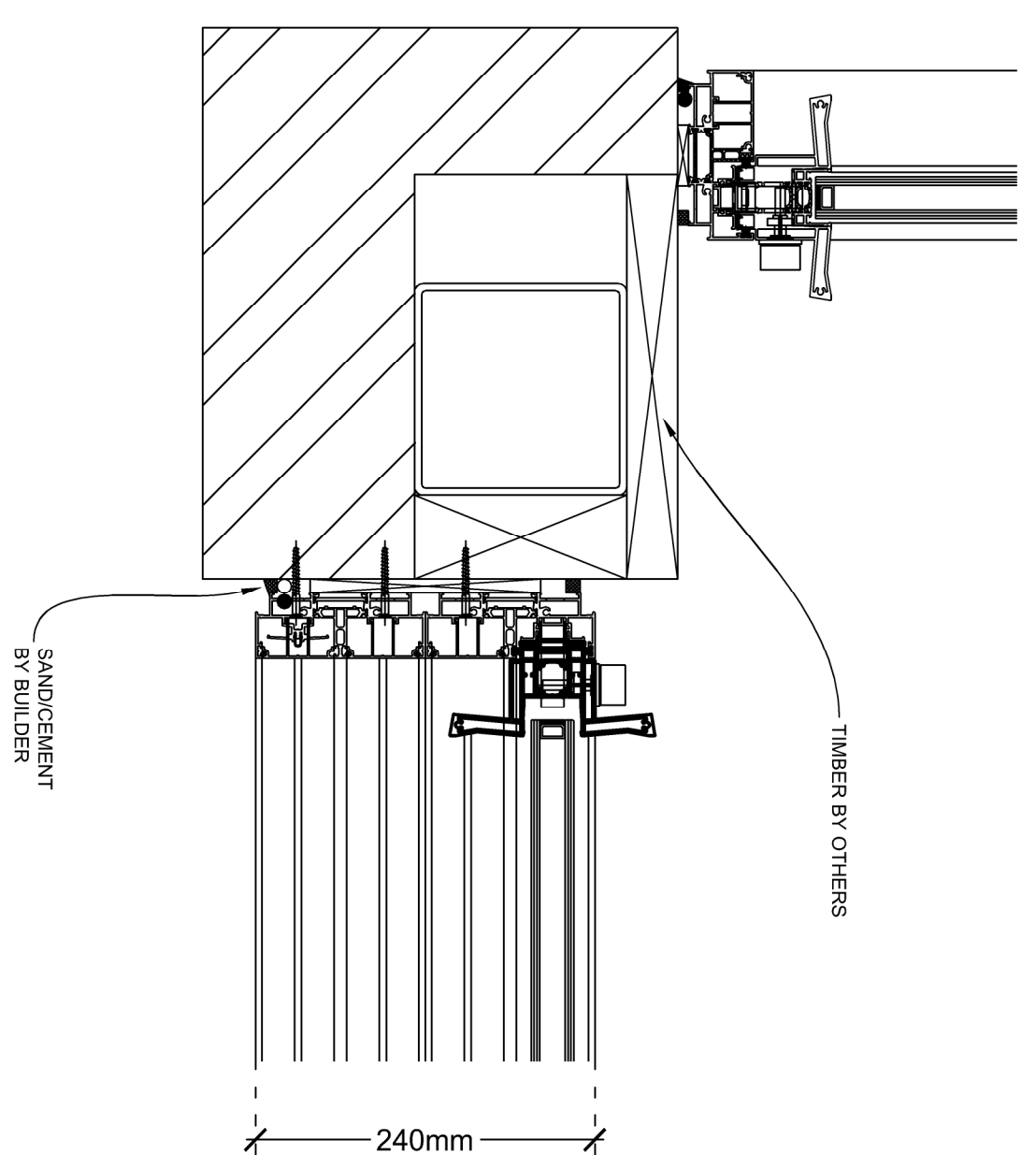

SPECIFICATION

MATERIAL	FUSION VISIONE MINIMAL (30mm)
FINISH	POLYESTER POWDER COATED RAL 7015 MATTE INTERPON D
GLASS	6mm CLEAR TOUGHENED EXT 16mm WARM EDGE SPACER BLACK 6mm CLEAR TOUGHENED LOW-E INT

GLAZING	BLACK GASKET
FIXING	BY NORTHOLT GLASS
FOUNTING	SILICONE
GEARING	

FITTINGS
RUNNING GEAR
SYSTEM RELATED HIGH SECURITY
MULTIPOINT LOCKING MECHANISM WITH
KEY LOCK TO INSIDE ONLY.
STAINLESS STEEL THUMB TURN
OPERATED FROM THE INSIDE ONLY.

ARCHITECT	ROMERS PARK CORNER DRIVE EAST MORSLEY KT24 6SE
CONTRACTOR	
TITLE	4 PANE SLIDING DOOR SET

DRAWN	DATE	SCALE
TRC	11.05.19	1:20 @ A1

NG ARCHITECTURAL
GLASS & ALUMINIUM SYSTEMS
UNIT 2, GALT TERN BUSINESS VILLAGE, HARBURLE ROAD
LIVERPOOL, MERseyside, L15 2SN
E-mail: info@northoltglass.co.uk FAX: 01895 238471
TEL: 01895 206650

DRG.NO. 19 2404 - 02